





The Volga-Dnepr Group is an international corporation consisting of three cargo airlines: Volga-Dnepr Airlines, AirBridgeCargo Airlines and Atran Airlines.

Volga-Dnepr Group is a major Russian airfreight carrier, and one of the world's top 15 international airfreight companies.

According to its 2016 results, Volga-Dnepr Group was ranked 10th among major airfreight carriers of the world in terms of its FTK performed. The Group has been the world leader in the oversize and heavy cargo market for many years.

Volga-Dnepr Group fleet consists of 17 Boeing-747F, 3 Boeing-737F, 12 An-124-100, 5 Il-76TD-90VD

WORLD LEADER



in the oversize and heavy cargo market

RANKED 10TH



among major airfreight carriers of the world in terms of its FTK performed

RANKED 1ST



among Russian airlines both in terms of cargo carried and cargo turnover

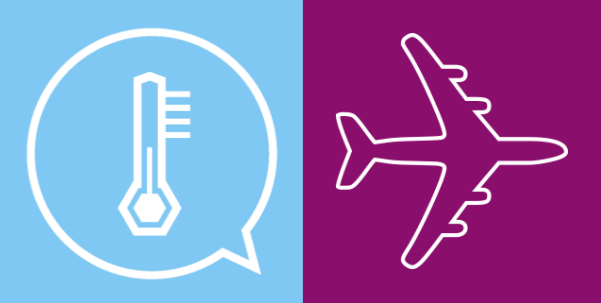

Work is the human activity of bringing value to society by way of its continuous cognition, aimed to prevent threats to humanity (country, organization, human being), threats to the present and the future.



Honesty is a fulfillment of obligations to oneself and others, expressed in one's intentions to perform the obligations as well as an evaluation of such performance.





- Creating **VALUE** for the Customers (representing the society) in the form of products/services of the Company being expressed in the Employee's personal workmanship (without delegation to anyone);
- Organized **COOPERATION** in accordance with regulations of division, specialization and cooperation of work which are used in the Company and also contracts between the Company and Customers, the Company and Suppliers;
- Receiving Customers' **RECOGNITION** for the value from the Company's services/products in generally accepted legal forms: money and other derivatives, barter; gratitude and other immaterial forms of recognition;
- Continuous cognition needed for the creating value for the Customer through the training, maintenance and transfer of **KNOWLEDGE**, scientific and inventive activity;
- Continuous development of the Employee's working abilities (intellectual, emotional, communicational, physical and energetic) through the constant **PERFECTION** (rationalization) of working processes and value created by them;
- Drawing out and preventing threats to existence and **DEVELOPMENT** of the Customers, Employees, Company and Suppliers;
- **HEALTH** maintenance as a base of working ability in balanced, rational, scientifically based use of time for work, training, rest and family.



Future-oriented
thinking



Hard work



Long-term
relationships



Transparency



Trust
and honesty



Management of the Group:
Moscow Office

CHARTER OPERATIONS

VOLGA-DNEPR AIRLINES

ВОЛГА  ДНЄПР

12

An-124

5

IL-76

SCHEDULED OPERATIONS



17

B-747F



3

B-747F

On ACMI basis



3

B-737F

Total: **39+1** aircraft

SUPPORTIVE SERVICES

Logistics Services:

Engineering Logistic Center

Long-haul trucking:

Volga-Trucks Division

Aircraft maintenance:

VD Technics

Foreign language training:

International Studies Division

Aviation insurance:

New Insurance Company



CHARTER OPERATIONS

12 freighters AN-124-100:

- Cargo compartment dimension 6,4 x 4,4 x 36,5 m
- World's largest series produced freighter

1091m³
CARGOHOLD

120t
MAX PAYLOAD

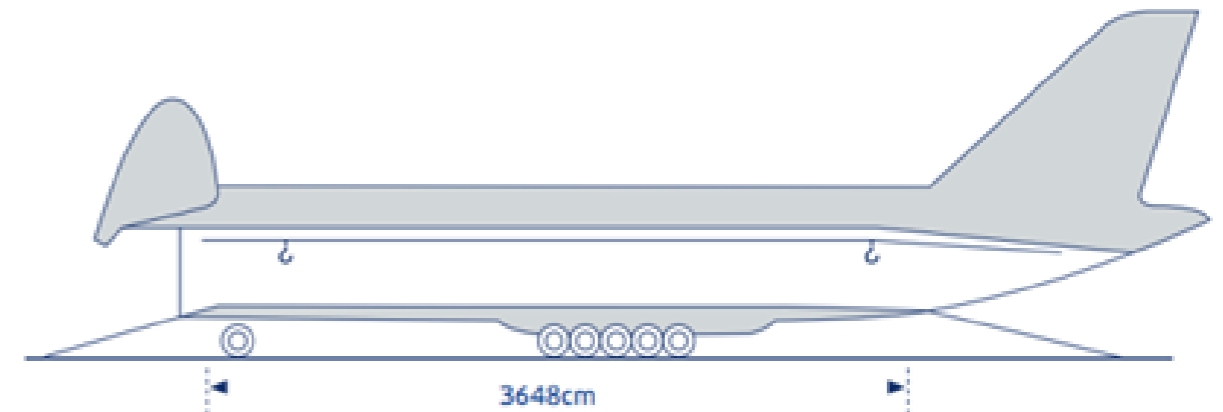
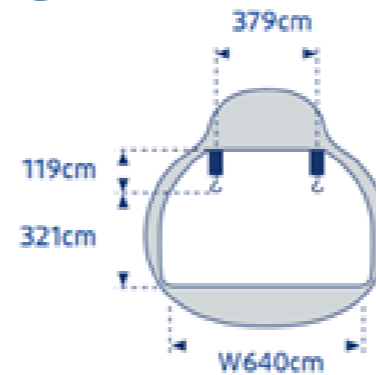

5 freighters IL76TD-90VD

- Cargo compartment dimension 3,4 x 3,45 x 20 m
- The NEW IL-76 has no operational restrictions
- Fully compliant with ICAO-standards

180m³
CARGOHOLD

50t
MAX PAYLOAD

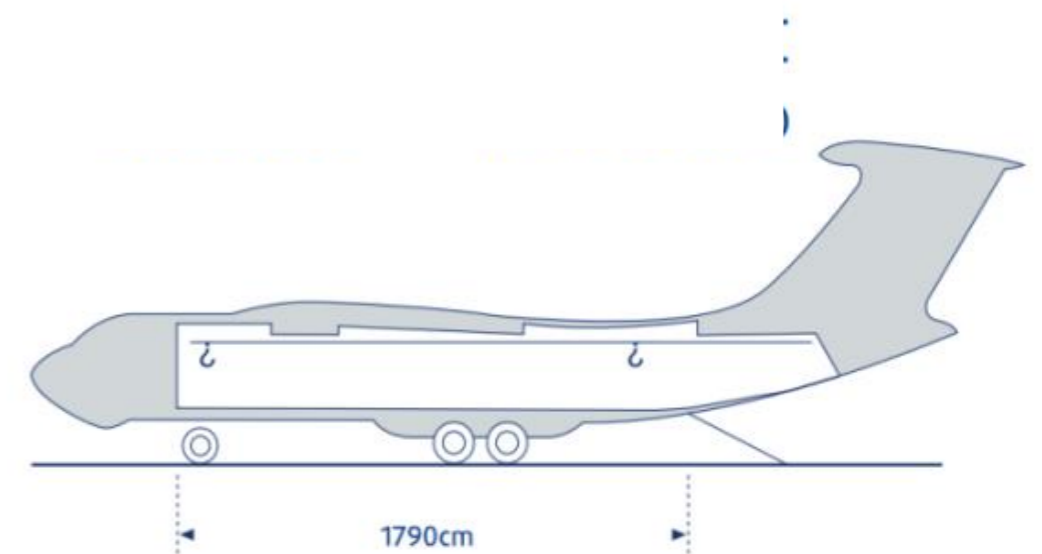
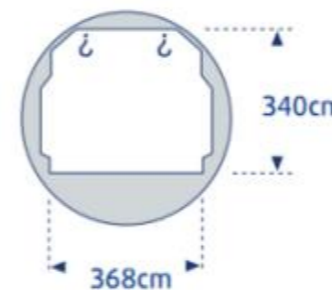



SCHEDULED OPERATIONS

17+3(ACMI) freighters B747F

- Especially for shipments on long-haul

121m³

CARGO HOLD
(tl. 36-45 pallets)

137t

MAX PAYLOAD

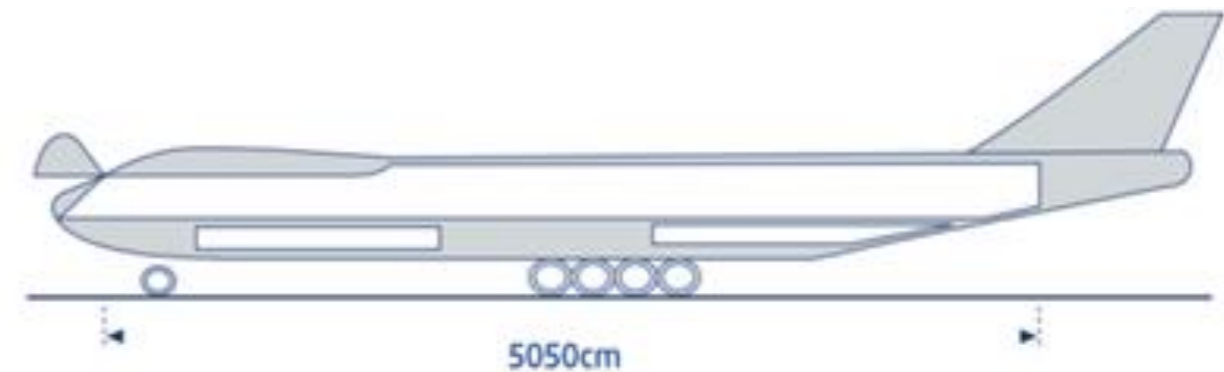
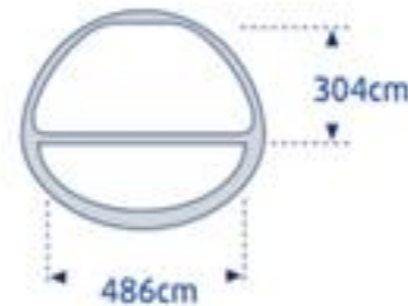

3 freighters B737

- For regional cargo uplift
- Short haul shuttle services

120m³

CARGO HOLD
(tl. 11 pallets)

19t

MAX PAYLOAD

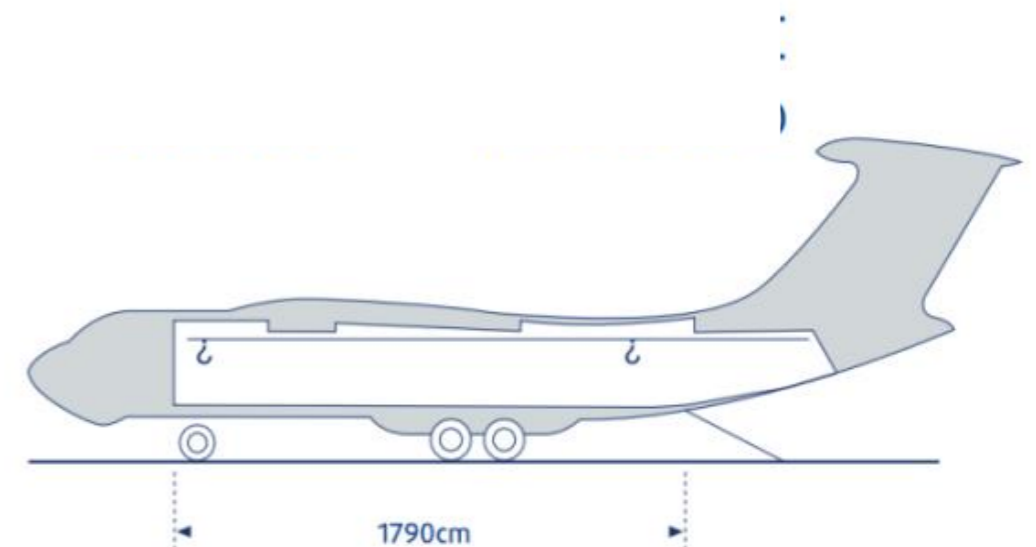
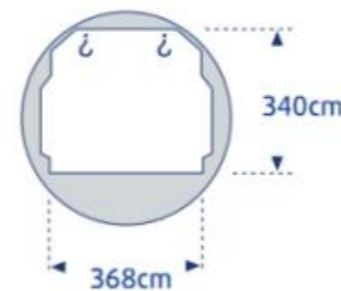



OUR BOEING FLEET

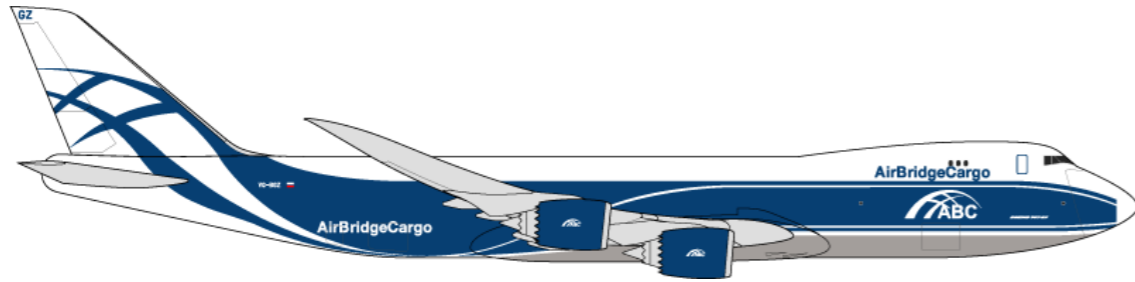
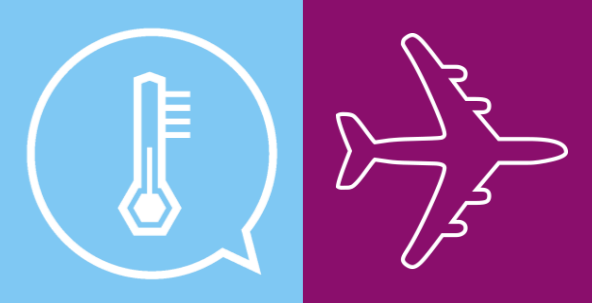

10
7

Boeing-747-8F

Boeing-747-400 ERF / 400F

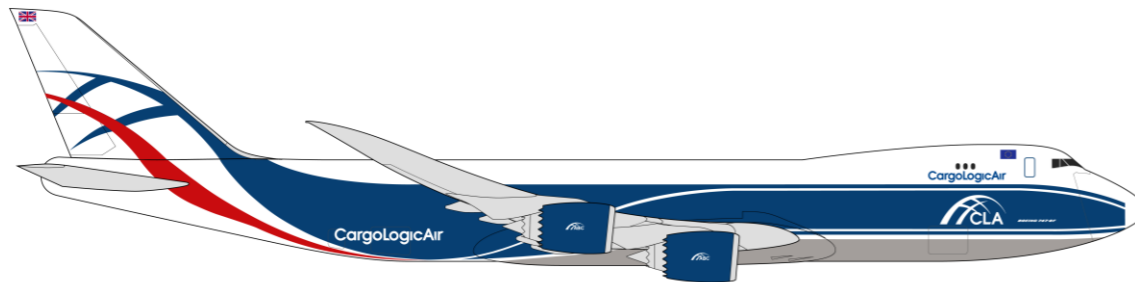

1
1+1*

Boeing-747-8F

Boeing-747-400 ERF / 400F

(*delivery 2Q2017)

On ACMI basis

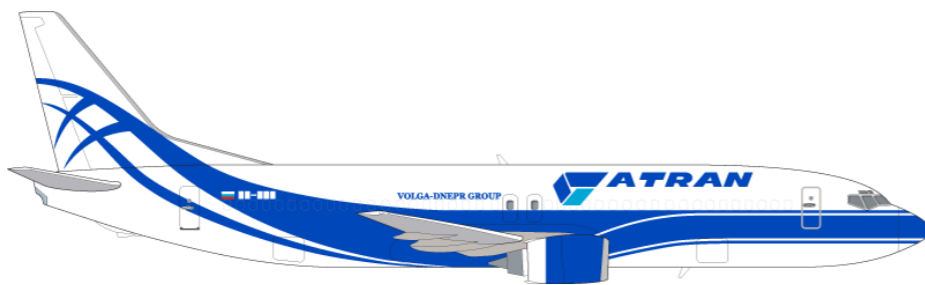

3

Boeing-737F

TOTAL FLEET – 22+1 AIRCRAFT

- One of the youngest fleet in the industry
- The 10th B-747-8F was delivered in April, 2017
- Meets all current operational standards for cargo operations
- The most modern wide-body cargo aircraft
- “GoGreen” strategy – low level of CO2 emissions
- Transportation of all types of special cargo



BOEING FLEET DEVELOPMENT

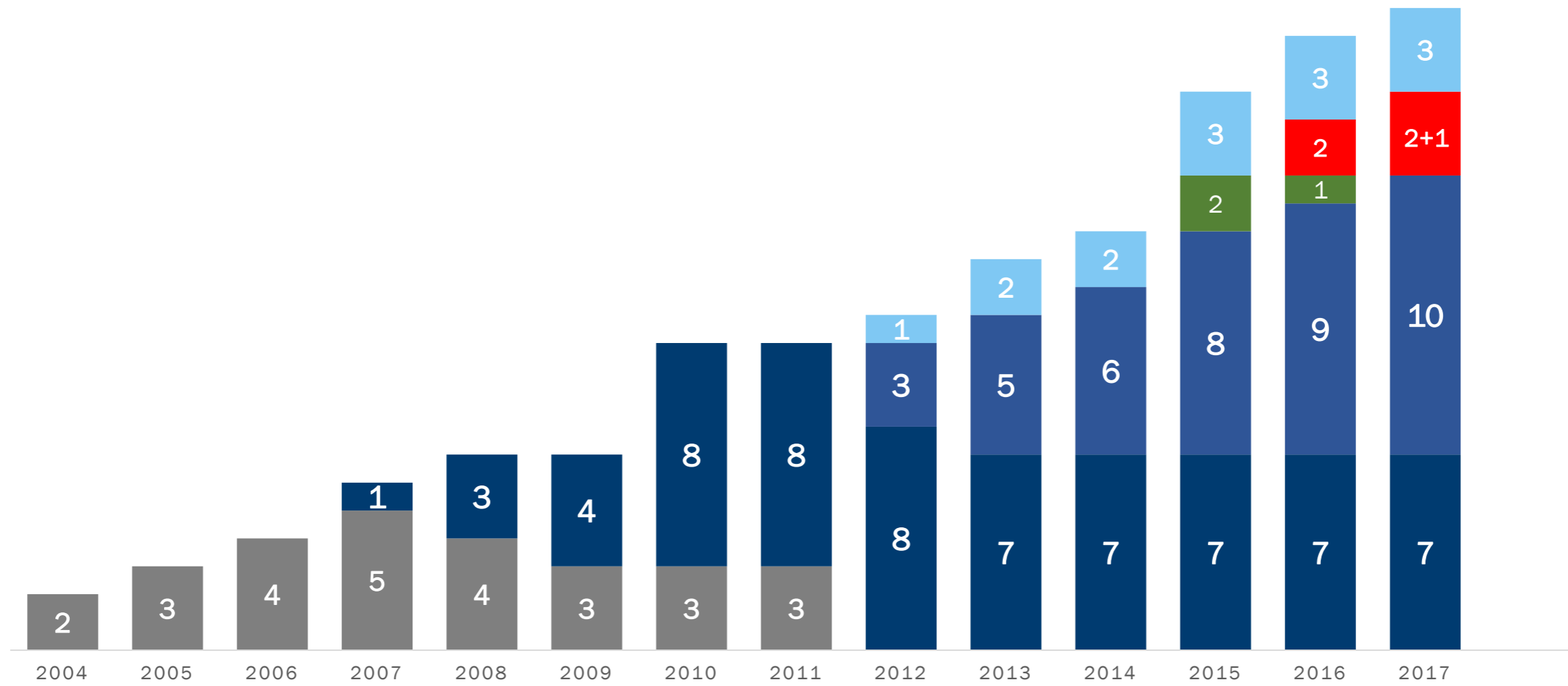

■ Boeing 747-200/300F

■ Boeing 747-400ERF/400F

■ Boeing 747-8F

■ ACMI B-747

■ CLA

■ Boeing 737

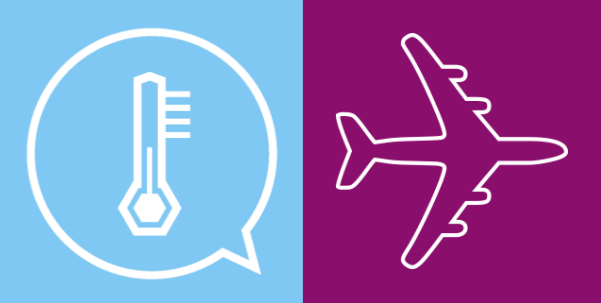

- Member of *Cool Chain Association*
- *IATA CEIV* (pharma) certified
- Compliance with *international quality standards* (IOSA, full member CargoIQ (C2K))
- High standards of *ground handling* operations and *security standards* for cargoes transported
- Qualified and *certified staff* for transportation of special cargoes
- *Individual* approach to customer *service*
- Special handling cargo is under *24/7 control*
- Hub in Moscow: *effective connections* to deliver cargo *worldwide*

abc XL



Whatever the size, weight or shape – we can transport it for you.

abc Pharma



We love being part of our mission to heal.

abc DG



Knowledge and precision that will give you an extra peace of mind.

abc Care

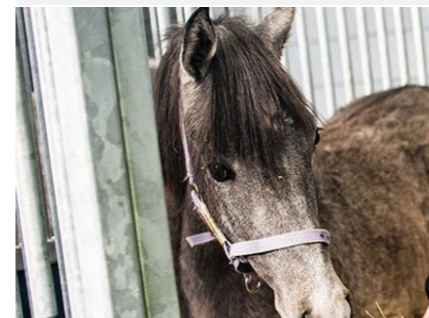

A commitment to animal welfare policies is at the core of our live cargo operations.

abc Fresh



Delivering joy, every single day.

abc Valuable

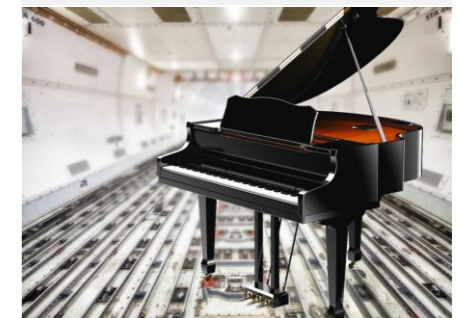

Valuable shipments travel safely and reliably with us.



B-737 frequencies

Origin	Destination	Weekly
SVO	MUC	9
	LGG	10
	MMX	1
VKO	CGN	5



DYNAMICS OF TONNAGE

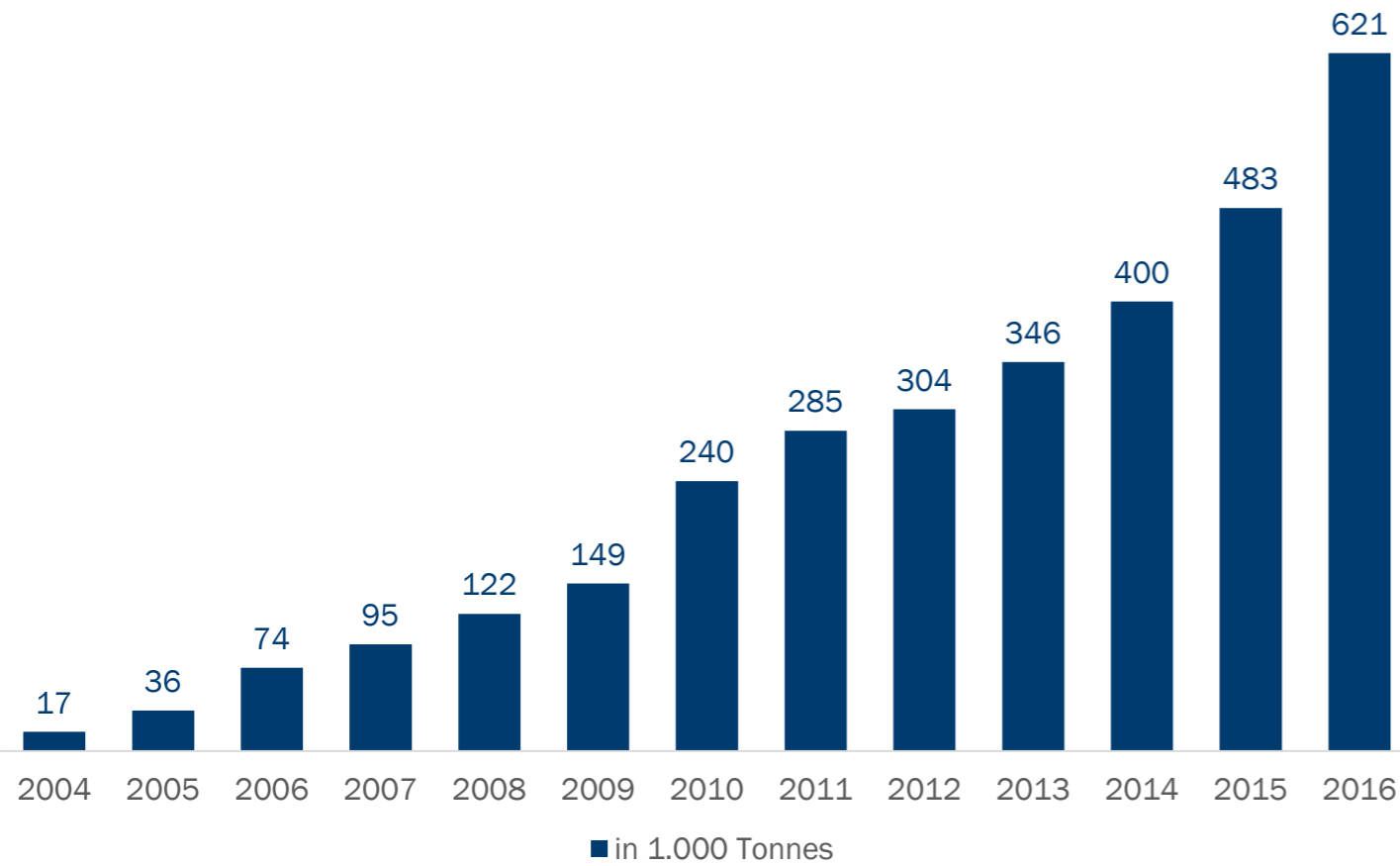

DYNAMICS OF FTK

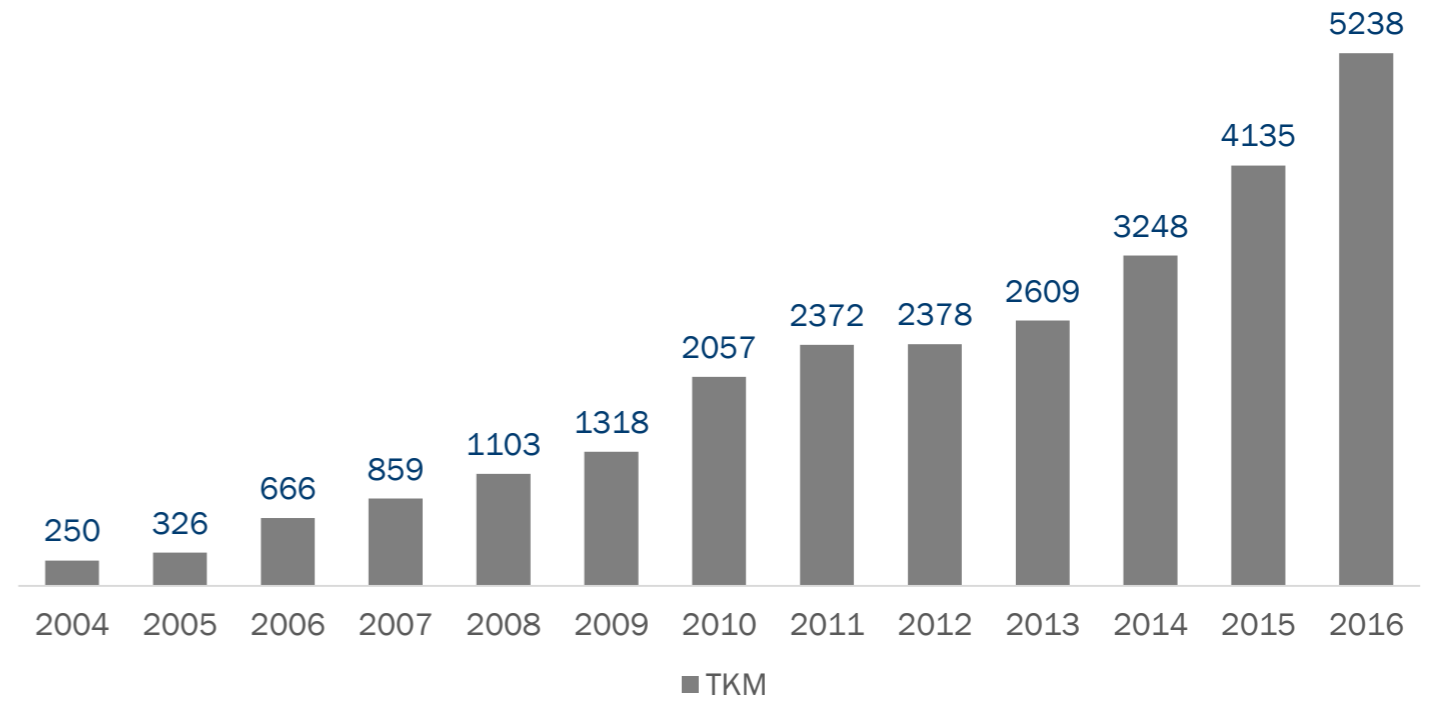

AirBridgeCargo Airlines is one of the fastest developing air cargo carriers in the world with consistently improving quality for our customers.



SVO HUB FACILITIES

- 3 warehouses in SVO
- 20 000 sq m – total area of warehouses in SVO
- first automated cargo handling system in Russia with three-dimensional cargo handling on several levels
- 24/7 video surveillance
- 137 cameras
- 99,98 Safety index
- TAPA certified

- Refrigerators for perishable cargo
- 380 cub m area for temperature controlled cargo
- Temperature control from -30C to +10C
- Dedicated pharmacy warehouse
- Dedicated area for dangerous goods



CARGO ENHANCED SECURITY

- High-tech goods and ULD are inspected for any damage by visual inspection or with the use of special tools
- In case of detection of any damage, an ABC representative is informed immediately
- The entire process of loading and unloading is under video surveillance

- In case of tail-to-tail operations at least two aviation security officers are present at the time of unloading, transporting and loading on another board
- Two security officers are permanently on duty to protect cargo, cargo storage and bandwidth access mode at the warehouse



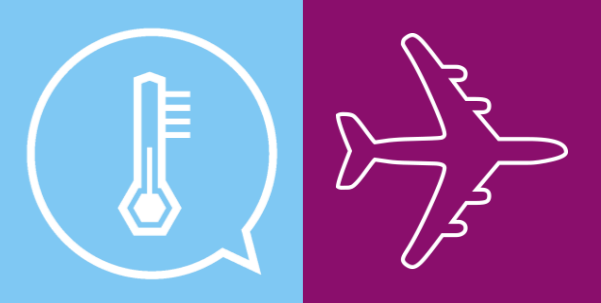

Moscow Hub Development (from 4th quarter 2017)

Total area:	42,300 sq. m
Pil:	3,482 cub. m
DGR:	6,412 cub. m
VAL:	435 cub. m
Handling capacity:	380,000 tons per year*
Scheduled Operational Start-up:	3rd quarter 2017



* The modular design of the complex allows to increase its capacity up to one million tons of cargo per year

THE FIRST AUTOMATED CARGO HANDLING SYSTEM IN RUSSIA

- To make full use of the available space and to ensure the cost and time efficiency of the cargo fleet the Complex will perform three-dimensional cargo handling on several levels.
- The modular design of the integrative components enables further improvements planning as well as rapid and efficient response to changing market conditions.
- Online controlled (through the web app) special storage zones to meet the critical requirements of temperature-sensitive medicines and perishable goods
- Security restricted area with biometric access control
- Sizeable four-storey Pallet Container Handling System (PCHS) with a storage area for 576 Unit Load Devices (ULD), 60 of which are dedicated positions for temperature-sensitive ULDs

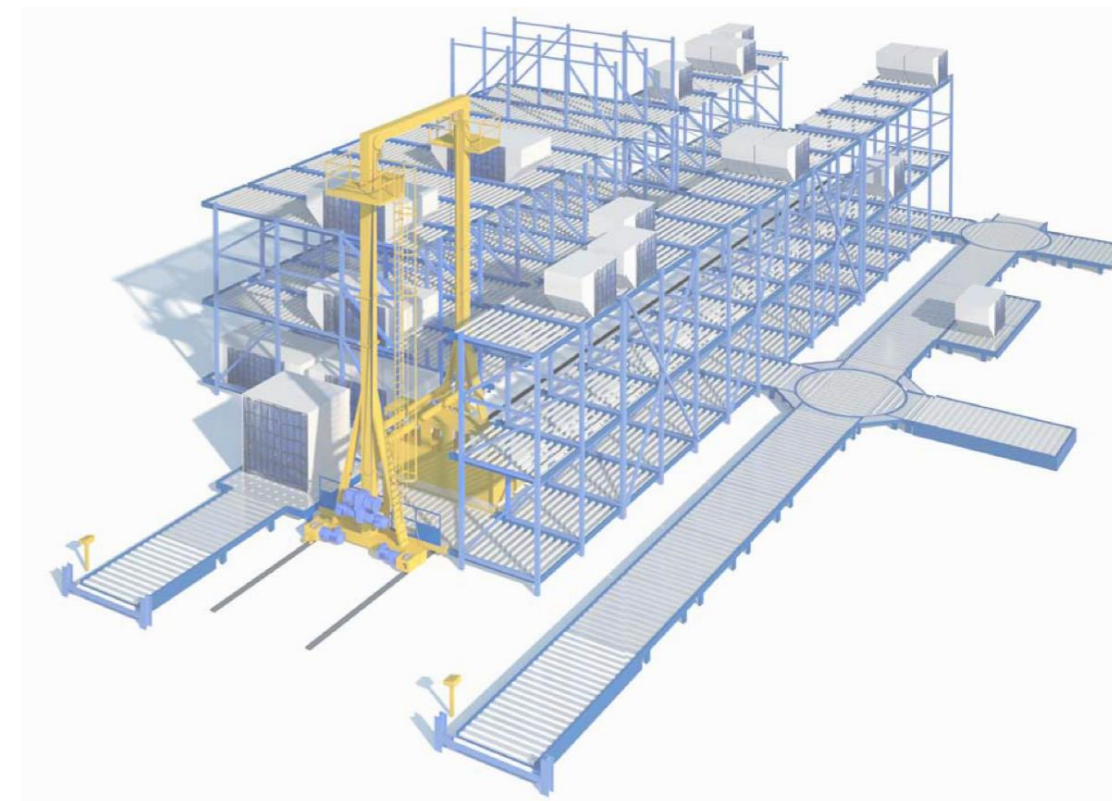



ABC in 2016



- Fleet development: one new B747-8F
- Route network development including via co-operations with partner airlines (new online stations: Seattle, Houston, Abu Dhabi, Phnom Penh, Oslo, London)
- Maintenance of high level quality of services
- IATA CEIV certification received
- Further development of heavy and outsize cargo services
- Close communication with customers on all levels including corporate
- Further development of sales infrastructure
- E-booking solutions via corporate website



ABC in 2017



- Continued growth through our Boeing partnership: Fleet development: +2 Boeing-747F - total fleet 18 a/c
- ABC growth rates exceeding market growth rates
- ABC network development:
 - Asia-US - increase of transpacific operations
 - APAC: Taipei, Saigon
 - Middle East: Abu-Dhabi, Dubai
- Development of sales infrastructure:
 - Consolidated Group sales and management structure
 - New structure for development of verticals
 - Increase of GSAs in offline countries
- Continuation of cost optimization programme to increase our competitiveness
- Transformation into a premium products carrier: focus on high-yield cargo
 - Pharma - organisation alignment, pharma product introduction
 - Off-size - new HQ and regional sales structure to improve responsiveness
 - Dangerous goods
- Maintenance of high-quality services
- Close communication with customers on all levels including corporate



THANK YOU FOR YOUR ATTENTION!