





The Volga-Dnepr Group is an international corporation consisting of three cargo airlines: Volga-Dnepr Airlines, AirBridgeCargo Airlines and Atran Airlines.

Volga-Dnepr Group is a major Russian airfreight carrier, and one of the world's top 15 international airfreight companies.

According to its 2017 results, Volga-Dnepr Group was ranked 9th among major airfreight carriers of the world based on FTK performance. The Group has been the world leader in the oversize and heavy cargo market for many years.

Volga-Dnepr Group fleet consists of 18 Boeing-747F, 3 Boeing-737F, 12 An-124-100, 5 Il-76TD-90VD

WORLD LEADER



in the oversize and heavy cargo market

RANKED 9TH



among major airfreight carriers of the world in terms of its FTK performed

RANKED 1ST



among Russian airlines both in terms of cargo carried and cargo turnover



Work is the human activity of bringing value to society by way of its continuous cognition, aimed to prevent threats to humanity (country, organization, human being), threats to the present and the future.



Honesty is a fulfillment of obligations to oneself and others, expressed in one's intentions to perform the obligations as well as an evaluation of such performance.





- Creating **VALUE** for the Customers (representing the society) in the form of products/services of the Company being expressed in the Employee's personal workmanship (without delegation to anyone);
- Organized **COOPERATION** in accordance with regulations of division, specialization and cooperation of work which are used in the Company and also contracts between the Company and Customers, the Company and Suppliers;
- Receiving Customers' **RECOGNITION** for the value from the Company's services/products in generally accepted legal forms: money and other derivatives, barter; gratitude and other immaterial forms of recognition;
- Continuous cognition needed for the creating value for the Customer through the training, maintenance and transfer of **KNOWLEDGE**, scientific and inventive activity;
- Continuous development of the Employee's working abilities (intellectual, emotional, communicational, physical and energetic) through the constant **PERFECTION** (rationalization) of working processes and value created by them;
- Drawing out and preventing threats to existence and **DEVELOPMENT** of the Customers, Employees, Company and Suppliers;
- **HEALTH** maintenance as a base of working ability in balanced, rational, scientifically based use of time for work, training, rest and family.



Future-oriented thinking



Hard work



Long-term relationships



Transparency



Trust and honesty



Management of the Group:

 Moscow Office – London Office 

CHARTER OPERATIONS

Volga  Dnepr

12 An-124

5 IL-76

SCHEDULED OPERATIONS

AIRBRIDGECARGO

18 B-747F

CARGOLOGICAIR

Strategic partner

3 B-747F

ATRAN

3 B-737F

Total: **41** aircraft

SUPPORTIVE SERVICES

Logistics Services:

Engineering Logistic Center

Long-haul trucking:

Volga-Trucks Division

Aircraft maintenance:

VD Technics

Corporate university:

Aviation and business training

Aviation insurance:

New Insurance Company



CHARTER OPERATIONS

12 freighters AN-124-100:

- Cargo compartment dimension 6,4 x 4,4 x 36,5 m
- World's largest series produced freighter

1091m³
CARGOHOLD

120t
MAX PAYLOAD

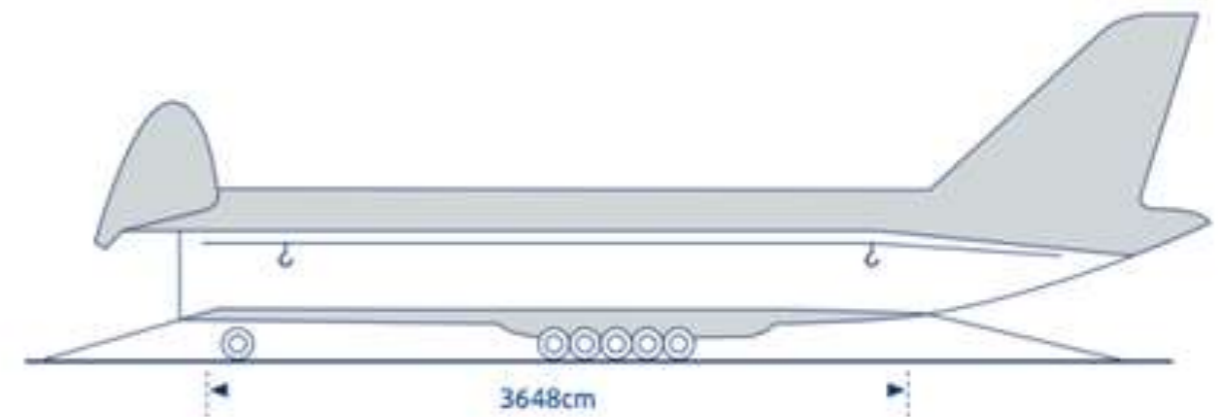

5 freighters IL76TD-90VD

- Cargo compartment dimension 3,4 x 3,45 x 20 m
- The NEW IL-76 has no operational restrictions
- Fully compliant with ICAO-standards

180m³
CARGOHOLD

50t
MAX PAYLOAD

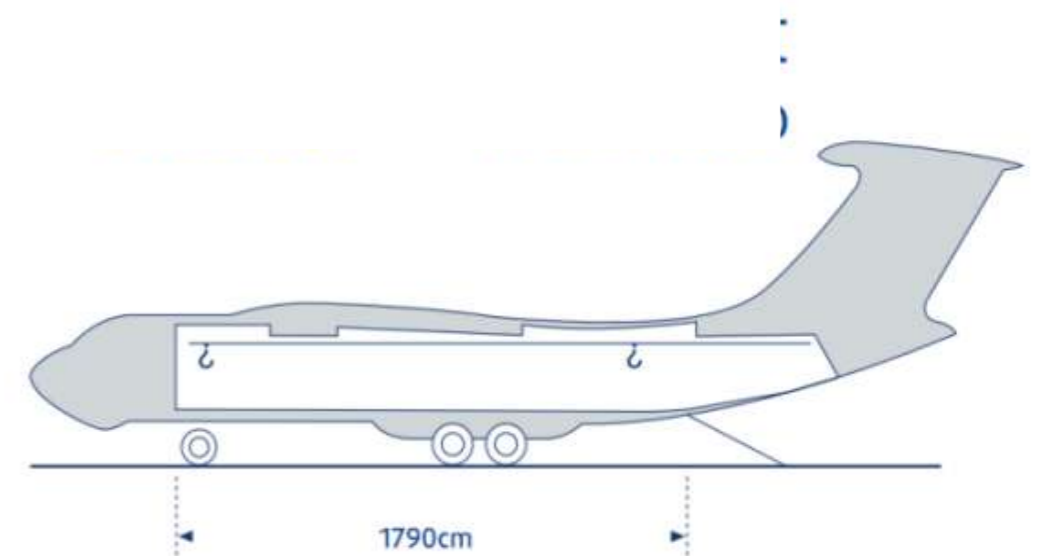
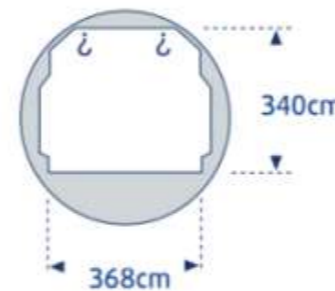



SCHEDULED OPERATIONS

18+3(ACMI) freighters B747F

- Ideal for long-haul shipments

36-45 pallets

139t
MAX PAYLOAD

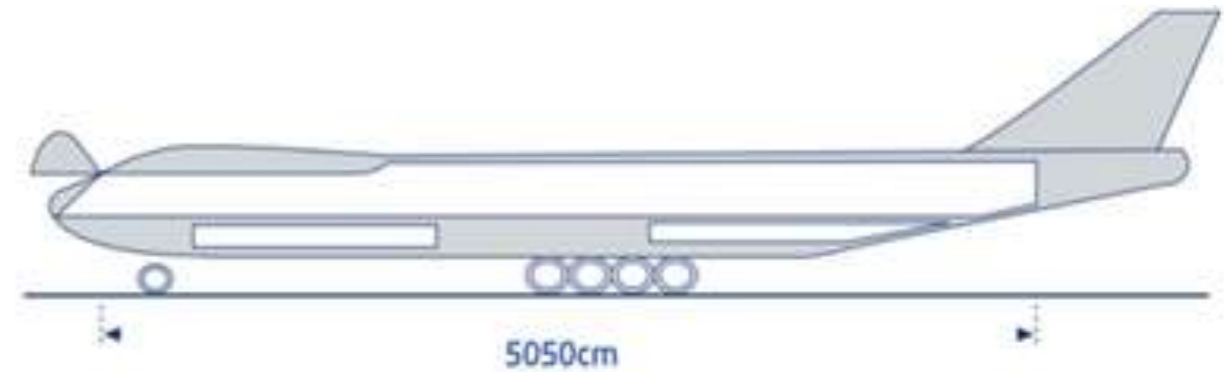
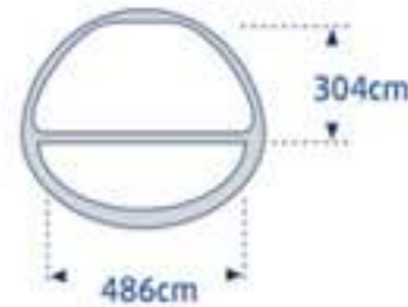

3 freighters B737

- For regional cargo uplift
- Short haul shuttle services

120m³
CARGO HOLD
(tl. 11 pallets)

19t
MAX PAYLOAD

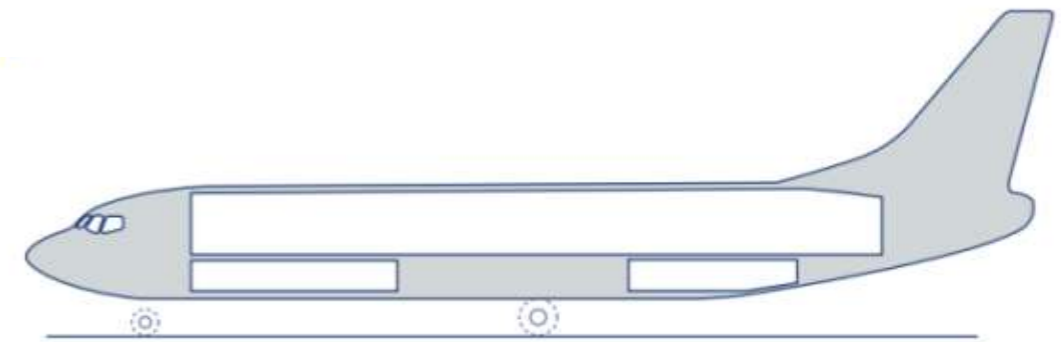
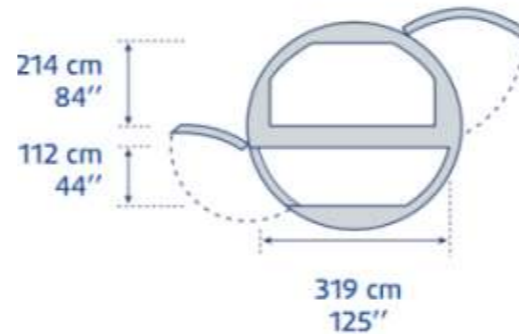



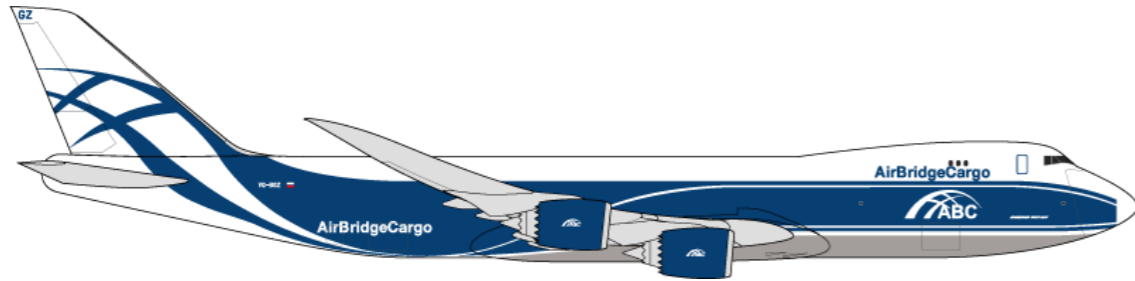

11
7

Boeing-747-8F
Boeing-747-400 ERF / 400F

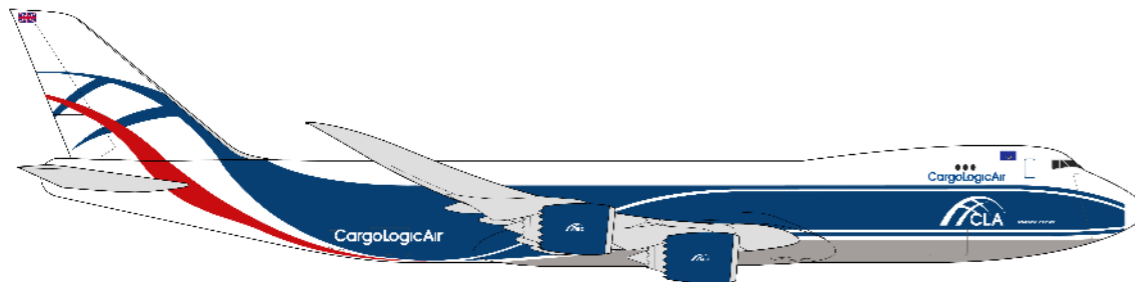

1
2

Boeing-747-8F
Boeing-747-400 ERF / 400F



3

Boeing-737F

TOTAL FLEET – 24 AIRCRAFT

- One of the youngest fleet in the industry
- The 11th B-747-8F was delivered in September, 2017
- Meets all current operational standards for cargo operations
- The most modern wide-body cargo aircraft
- “GoGreen” strategy – low level of CO2 emissions
- Transportation of all types of special cargo



BOEING FLEET DEVELOPMENT

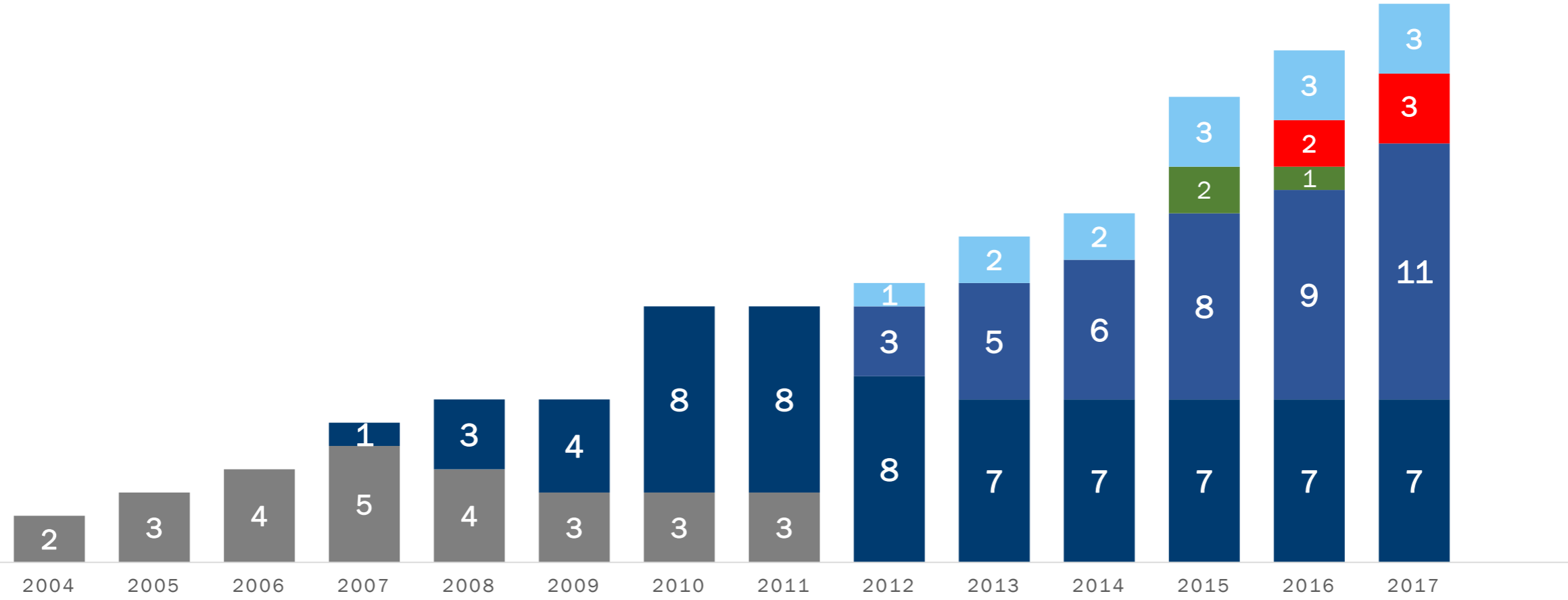

- Boeing 747-200/300F
- Boeing 747-400ERF/400F
- Boeing 747-8F
- ACMI B-747
- CLA
- Boeing 737



AirBridgeCargo (ABC) is the leading all-cargo carrier in Russia and operates among the top ten international cargo airlines worldwide.

Quality focus

- **IATA** and **IOSA** certified, full compliance with all international/internal safety guidelines and quality standards (**Cargo IQ**)
- Member of **Cool Chain Association**
- **IATA CEIV** (pharma) and **QEP** certified
- **Qualified** and **certified** team of **logistics practitioners** for transportation of general and special cargoes
- **24/7/365 Control Tower (CT)** operation to monitor and manage transportation special cargo consignments

Achievements and advantages

- More than 13 years of consecutive growth
- Over **30 airfreight destinations** with effective **connectivity options** through hub in Moscow and 48 hour delivery time
- 1,300 **cargo professionals** worldwide
- **Customized logistics** solutions for transportation of general and special cargo
- State-of-the-art **Boeing 747 fleet**
- Logistics solutions, complemented by extensive network of ABC **interline partners** and **trucking companies** worldwide

abc | **XL7** over size



Whatever the size, weight or shape – we can transport it for you.

abc | **pharma**



We love being part of our mission to heal.

abc | **DG**



Knowledge and precision that will give you an extra peace of mind.

abc | **care**



A commitment to animal welfare policies is at the core of our live cargo operations.

abc | **fresh**



Delivering joy, every single day.

abc | **valuable**



Valuable shipments travel safely and reliably with us.



Boeing-747F Route Network

Schedule Aug, 2018

including **CLA route network**
(strategic partner)

Numbers of frequencies
per week

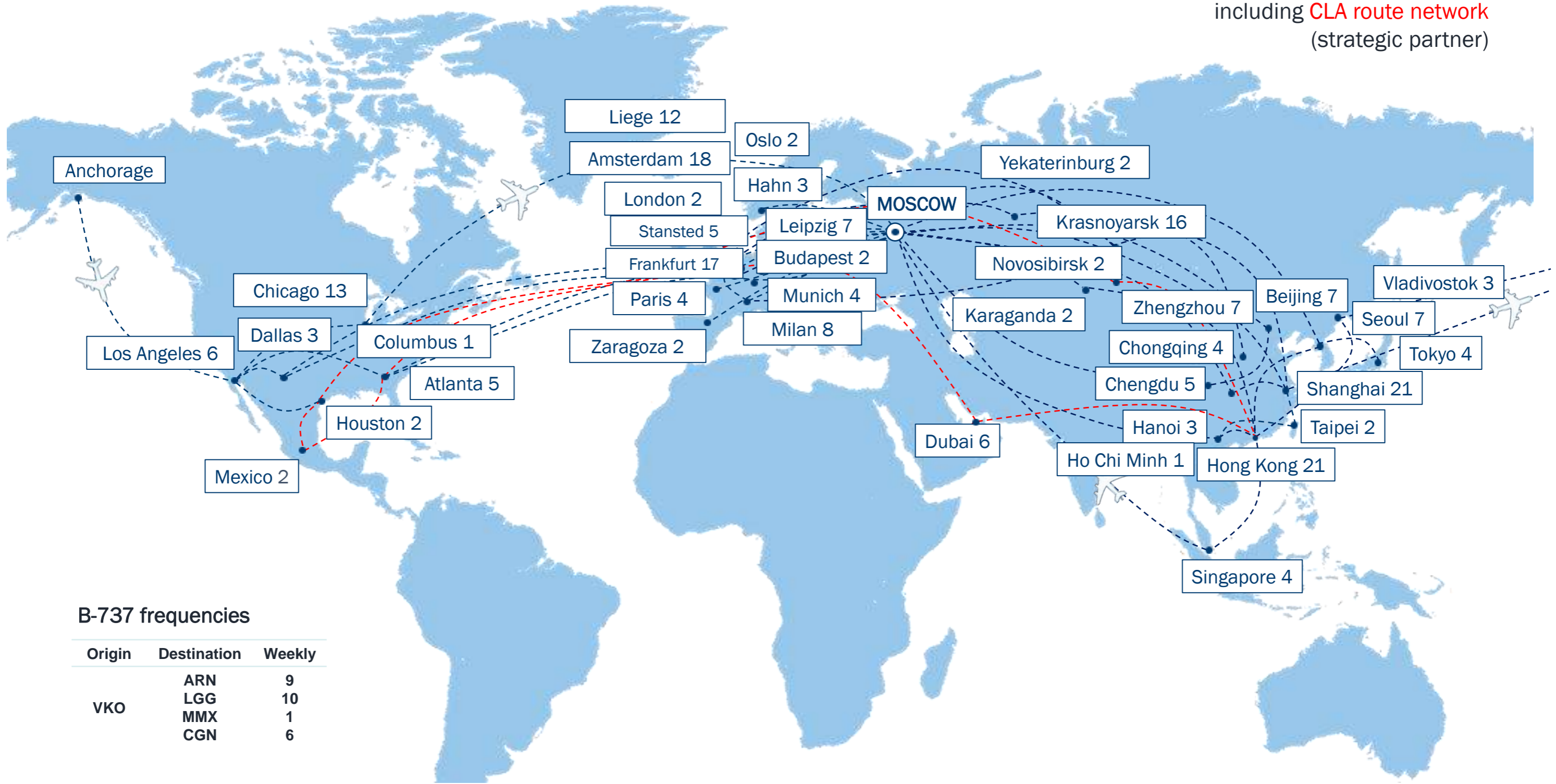

B-737 frequencies

Origin	Destination	Weekly
VKO	ARN	9
	LGG	10
	MMX	1
	CGN	6



DYNAMICS OF TONNAGE

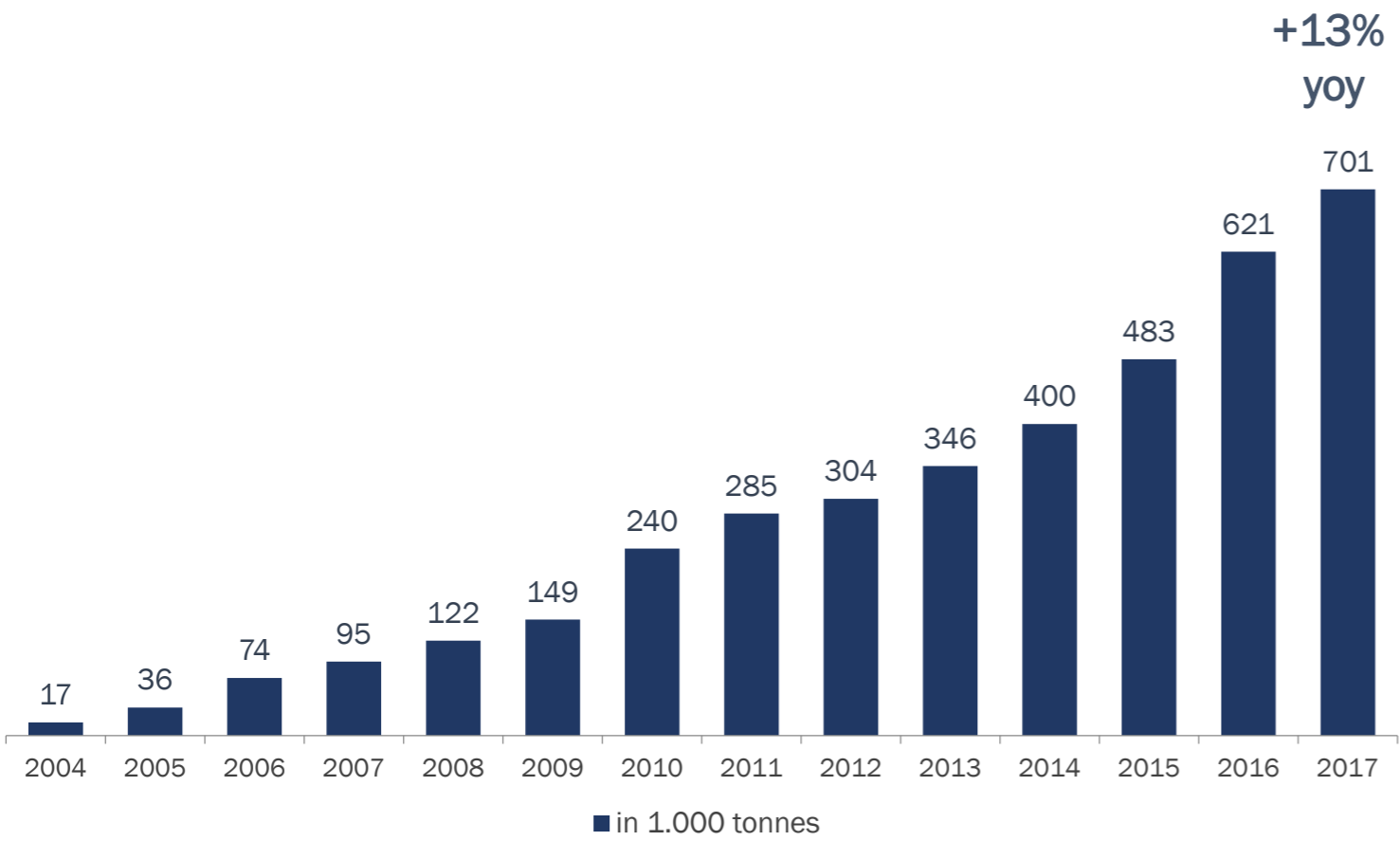

DYNAMICS OF FTK

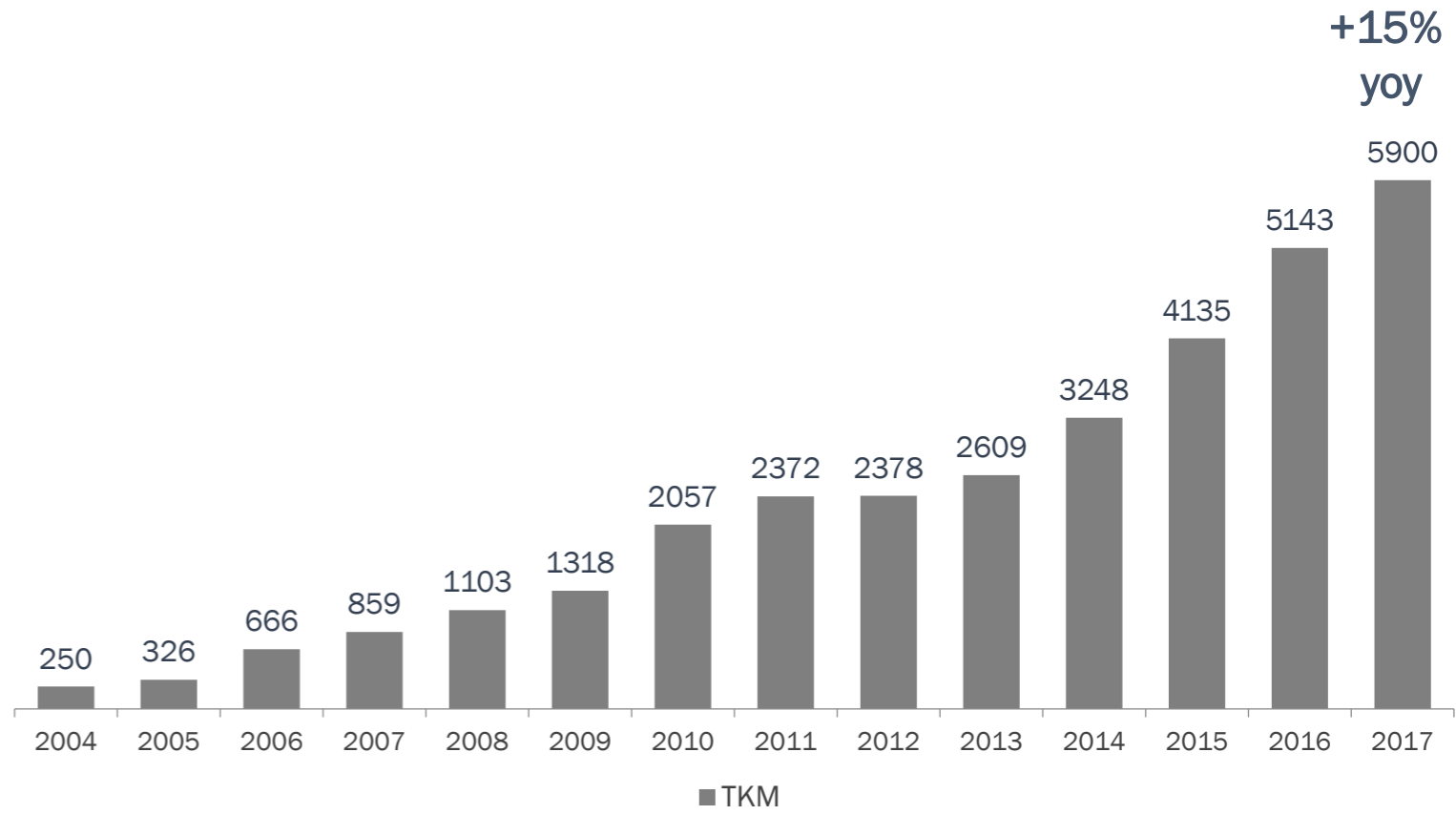

AirBridgeCargo Airlines is one of the fastest developing air cargo carriers in the world with consistently improving quality for our customers.



Logistic solutions based on your needs:

You like improving lives.

abc Pharma for all your healthcare shipments



- Dedicated, skilled staff trained in handling healthcare products



- Boeing 747-8 and 747-400 with three compartments enabling different temperature settings from 4° C to 29° C



- Full compliance with IATA TCR and CEIV certification



- ABC has gained Envirotainer QEP accreditation for 7 of its online stations

- Exact temperature monitoring from acceptance to delivery

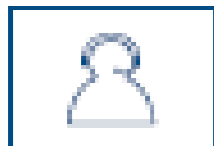

- Special packaging solutions and thermal blankets for palletized shipments

- Adoption of the latest digital technologies (Sky Fresh for automated notifications, temperature data loggers to monitor consignment conditions, etc)



- Customer service support, online track&trace option for all shipments

- High-tech pharma hub at Moscow Sheremetyevo International Airport with effective connections to deliver cargo worldwide

- Tailor-made logistics solutions based on your individual requirements

abcPharma products:

abc PHARMA Active

abc PHARMA Passive





Your benefits at a glance

- On-site technical manufacturer's inspection and consultation
- Highly customized logistics solutions (from design and manufacture to packaging and delivery)
- Nose door loading capabilities
- Certified, highly skilled staff across the entire network
- Door-to-door solutions
- 3D modeling for load planning of complex shipments
- Possibility of cargo attendants on board and at shipper's site
- Special operating procedures for the transportation of aviation engines
- Full compliance with IATA, ICAO, Boeing guidelines and internal safety policies
- Enhanced security measures and 24/7 surveillance of shipments
- Customer service support, online track&trace option for all shipments

Aerospace Industry Specialized solutions:

- Commercial aviation aircraft engines, in compliance with manufacturer handling guidelines
- Vast experience in the transportation of satellite systems, small aircrafts, fuselages, stabilizers, ailerons, etc.
- Express delivery of AOG spare parts

Oil & Gas Industry Specialized solutions:

- Carriage of pipes, generators, pumps and other extremely large and heavy drilling or offshore equipment
- Dedicated charter services or re-routing in case of rig down situations

You like knowing you're in good hands.

abc XL logistics solutions for oversize and heavy cargo





Your benefits at a glance

- Full compliance with IATA Dangerous Goods Regulations and ICAO Technical Instructions for the Safe Transport of Dangerous Goods by Air, Doc 9284 AN/905
- Fully certified to transport all Classes of dangerous goods, including explosives and radioactive materials
- Acceptance of all types of lithium metal and lithium-ion batteries, both single and in an equipment, including cases under special provisions A88, A99
- Transportation of hybrid vehicles with lithium-ion battery engines
- Possibility to obtain exemptions and approvals for carriage of certain goods
- Certified and trained personnel across the entire ABC network
- Highly customizable logistics solutions
- 24/7 surveillance of shipments

abc | DGLi⁺ – empowered to deliver

ABC services for transportation of Lithium batteries

- Acceptance of all types of lithium metal and lithium-ion batteries, both single and in an equipment, throughout entire ABC network, including cases under special provisions A88, A99
- No additional restrictions on transportation of lithium batteries
- Assistance with testing for safe transportation and obtaining of respective report (UN Manual of Tests and Criteria, Part III, subsection 38.3)
- Special training course ‘Transportation of lithium batteries’ by certified trainers
- Advisory support with respect to ready-for-carriage procedures

You like having an extra peace of mind
abcDG logistics solutions for dangerous goods





Special attention for special cargo

AirBridgeCargo Airlines has established a new 24/7/365 Control Tower (CT) operation to monitor special cargo consignments and to proactively respond to service disruptions in order to ensure ABC consistently meets customers' delivery deadlines.

Managed by a team of fully trained supply chain specialists and based in Moscow, HQ the Control Tower provides:

- real-time, round-the-clock monitoring of all cargo movements throughout the entire transportation process across ABC's network
- checkup of ABC's fleet technical condition (temperature control system, cargo handling system readiness)
- schedule alignment and control for priority delivery of special cargo
- communication with ABC specialists from different departments and customers in case of deviations for prompt response
- cargo status updates and reports
- CT personnel availability 24/7 via e-mail, skype or direct phone line





SVO HUB FACILITIES

- 3 warehouses in SVO
- 20 000 sq m – total area of warehouses in SVO
- first automated cargo handling system in Russia with three-dimensional cargo handling on several levels
- 24/7 video surveillance
- 137 cameras
- 99,98 Safety index
- TAPA certified
- Refrigerators for perishable cargo
- 380 cub m area for temperature controlled cargo
- Temperature control from -30C to +10C
- Dedicated pharmacy warehouse
- Dedicated area for dangerous goods



CARGO ENHANCED SECURITY

- High-tech goods and ULD are inspected for any damage by visual inspection or with the use of special tools
- In case of detection of any damage, an ABC representative is informed immediately
- The entire process of loading and unloading is under video surveillance
- In case of tail-to-tail operations at least two aviation security officers are present at the time of unloading, transporting and loading on another board
- Two security officers are permanently on duty to protect cargo, cargo storage and bandwidth access mode at the warehouse





Moscow Hub Development

Total area:	42,300 sq. m
Pil:	3,482 cub. m
DGR:	6,412 cub. m
VAL:	435 cub. m
Handling capacity:	380,000 tons per year*
Scheduled Operational Start-up:	3rd quarter 2017



* The modular design of the complex allows to increase its capacity up to one million tons of cargo per year

THE FIRST AUTOMATED CARGO HANDLING SYSTEM IN RUSSIA

- To make full use of the available space and to ensure the cost and time efficiency of the cargo fleet the Complex will perform three-dimensional cargo handling on several levels.
- The modular design of the integrative components enables further improvements planning as well as rapid and efficient response to changing market conditions.
- Online controlled (through the web app) special storage zones to meet the critical requirements of temperature-sensitive medicines and perishable goods
- Security restricted area with biometric access control
- Sizeable four-storey Pallet Container Handling System (PCHS) with a storage area for 576 Unit Load Devices (ULD), 60 of which are dedicated positions for temperature-sensitive ULDs

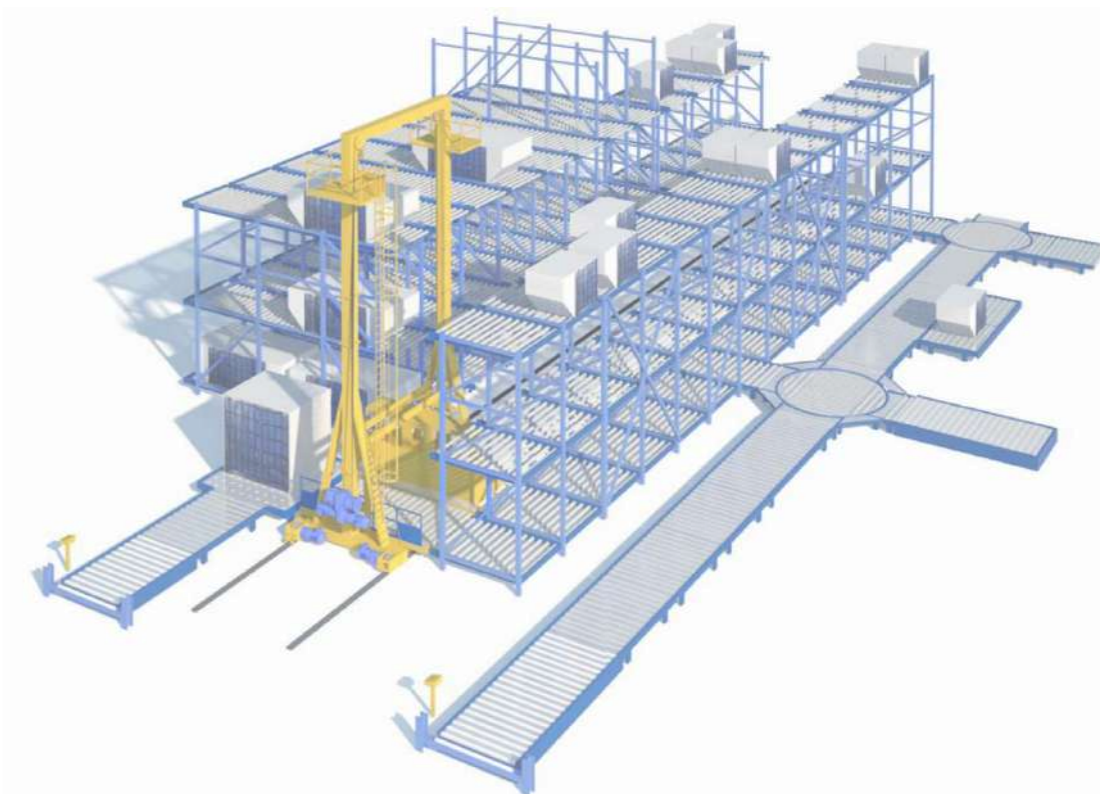



- Fleet development: +2 Boeing-747F - total fleet 18 a/c
- ABC growth rates exceeding market growth rates +14% (in tonnage)
- # 9 airline in the world (excluding integrators)
- ABC network development together with the strategic airline partner CLA:
 - Asia-US - increase of transpacific operations
 - APAC: Taipei
 - Middle East: Abu-Dhabi, Dubai, Tel Aviv
 - Europe: launch of operations into cargo-friendly airports: Liege, increase of Munich frequencies
 - Americas: launch of Mexico
- Transformation into a premium products carrier: focus on special cargo transportation
 - Pharma - organization alignment, pharma product introduction, QEP certification of 7 stations, adoption of digital technologies (SkyFresh automated notifications), participation in various pharma initiatives
 - Off-size - new HQ and regional sales structure to improve responsiveness
 - Dangerous goods
 - Establishment of control tower 24/7 for special cargo shipments
- Development of sales infrastructure:
 - Consolidated Group sales and management structure
 - New structure for development of verticals
- Continuation of cost optimization programme to increase our competitiveness
- Maintenance of high-quality services
- Continuous investment in HR (internal and external training programmes)
- Close communication with customers on all levels including corporate



- Further network development together with the strategic airline partner CLA:
 - Asia-US - increase of transpacific operations
 - Increase of presence in Middle East
 - Increase of stations in Europe (introduction of cargo-friendly airports)
- Further digitalization of transportation processes
- Further improvement of quality of special cargo handling
- Pharma - QEP certification of the stations, introduction of online data temperature loggers
- Dedicated teams of professionals for Off-size, Dangerous goods, Live Animals and other special cargo
- Further development of Control tower 24/7 for special cargo shipments
- Continuation of cost optimization programme to increase our competitiveness
- Close communication with customers on all levels including corporate



THANK YOU FOR YOUR ATTENTION!